

Glass and Aluminium works

ANNA STAR

✉ Email

info@ana-grp.com

☎ Telephone

+966558490607



Website

www.ana-grp.com

CONTENT

-  INTRODUCTION
-  PRODUCTS
-  ORGANIZATION CHART
-  MANUFACTURING FACILITIES
-  PROJECTS FACILITIES
-  FACTORY CERTIFICATES
-  MATERIAL APPROVALS





INTRODUCTION



ANNA STAR is considered as one of the most reputable Saudi companies in the field of developing, manufacturing, and installing aluminum glazing windows, doors, curtain walls, skylights, cladding and kitchen cabinets to service the Saudi market and the GCC market.

ANNA STAR operation has started early 2008, and throughout the years expanded tremendously to add:

- Upstream production lines enabling more control on raw material prices & Quality. -
- Horizontal expansion with new products and options to expand its market share.

With an entrepreneurial spirit **ANNA STAR** proudly served a diverse and distinguished clientele, large corporations and small enterprises, governmental institutions, health organizations hospitality facilities, companies and residential Saudi clients and international ones.

OUR VISION

To provide superior solutions for Architectural Opening and Curtain Walls and Kitchen Cabinets through Research and Development, Innovative Production Technology, State of the Art equipment and highly motivated employees, thereby sustaining our profits and creating long term value for our investors, business partners and employees.

OUR MISSION

- ✓ To manage and further develop our expertise.
- ✓ To achieve highest operational efficiency.
- ✓ To meet our customers best expectations.
- ✓ To manage and further develop our expertise.

PRODUCTION LINES

The Production of Windows, Doors , Curtain Walls & Kitchen Cabinets, consist of 5 main fabrication facilities which are:

- 1 - Standard Windows Fabrication lines.
- 2 - Non Standard Windows Fabrication.
- 3 - A curtain walls, skylights & Kitchen Cabinets and aluminium doors design fabrication line.
- 4 - Auxiliary Products Fabrication lines.
- 5 - Hardware Assembly.





AVERAGE TON PER YEAR

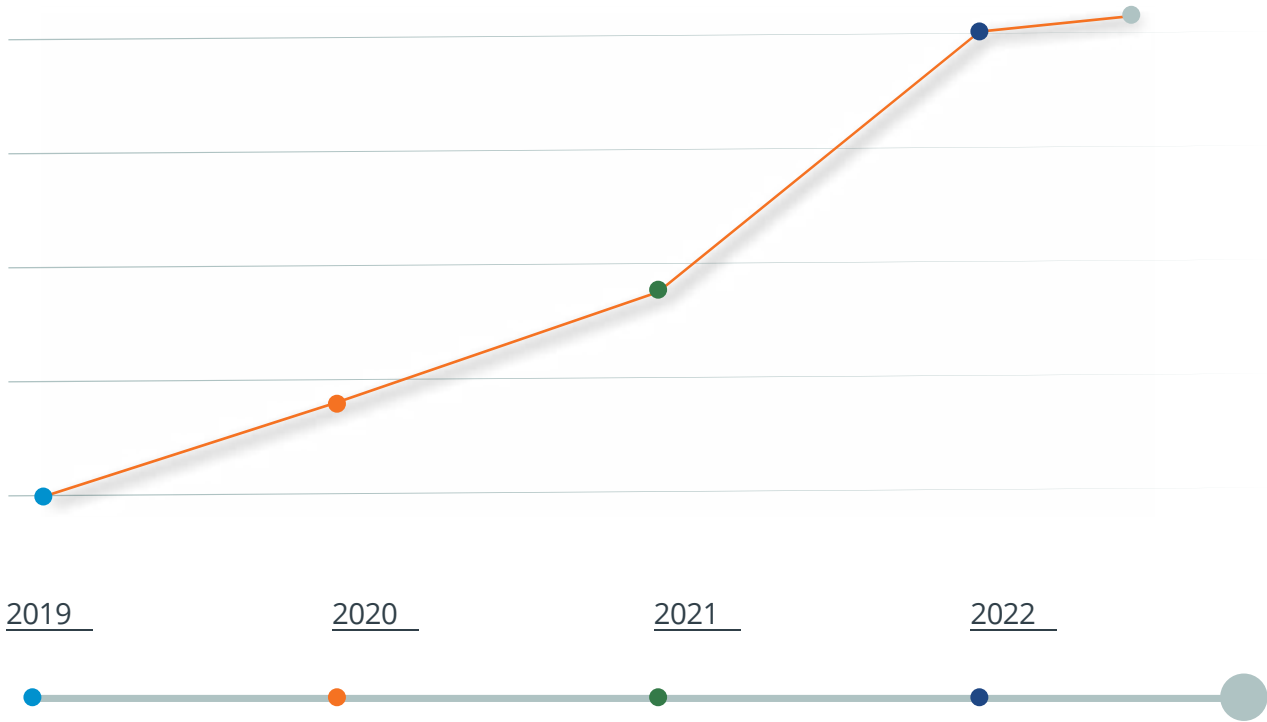

Year	Average Ton / year
2019	AROUND 26 Aluminum Ton / year
2020	AROUND 133 Aluminum Ton / year
2021	AROUND 212 Aluminum Ton / year
2022	AROUND 350 Aluminum Ton / year

ANNA STARBUILT ALUMINUM FACTORY

PRODUCTION ELEMENTS

- 1 - Sawing machines.
- 2 - Milling and drilling machines.
- 3 - Corner assembly machines.
- 4 - Automatic bending machines.
- 5 - Die casting facility.
- 6 - CNC profile processing machine.
- 7 - CNC Aluminum sheet processing machine.
- 8 - Quality control supervisors and inspection according to the International standard specifications.



OUR SERVICES

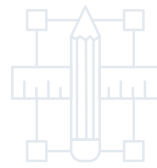

DESIGN

Engineering software called “ORGA data” is used to match all types of engineering designs with Saudi engineering codes.



MANUFACTURE

All varieties of aluminum are produced using high-tech machinery to provide high-quality results.



SUPPLY

ANNA STAR has a substantial amount of logistical resources that can reach to client project locations.

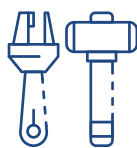

APPLY

ANNA STAR has a knowledgeable staff prepared to offer installation services to our client in various locations throughout Saudi Arabia.



PRODUCTS

ANNA STARBUILT

ALUMINUM FACTORY





ANNA STARBUILT ALUMINUM FACTORY



HINGED

SYSTEMS

HINGED
52MM



HINGED DOOR COPLANER

HINGED
45MM



HINGED DOOR

HINGED
52MM



HINGED WINDOWS

HINGED
45MM



HINGED WINDOWS

HINGED
52MM



HINGED DOORS OVERLAP

ANNA STARBUILT ALUMINUM FACTORY



SLIDING
SYSTEMS

123 THERMAL BREAK
FLYSCREEN INSIDE

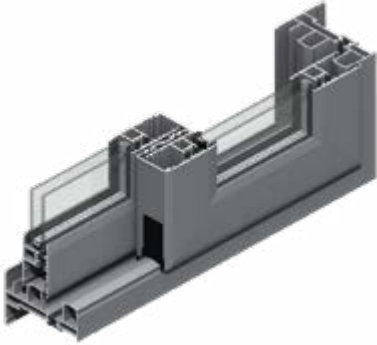

SLIDING WINDOW & DOOR

123 THERMAL BREAK
FLYSCREEN OUTSIDE

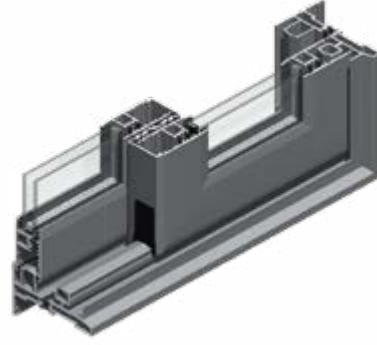

SLIDING WINDOW & DOOR

THERMAL
83 SL INSIDE



SLIDING WINDOW

THERMAL
83 SL OUTSIDE

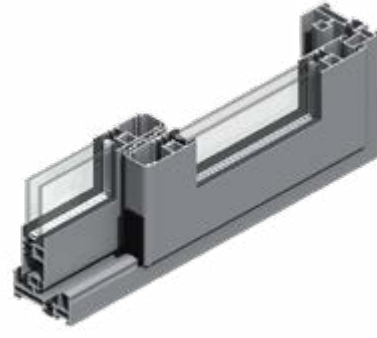

SLIDING WINDOW

THERMAL
97 SL

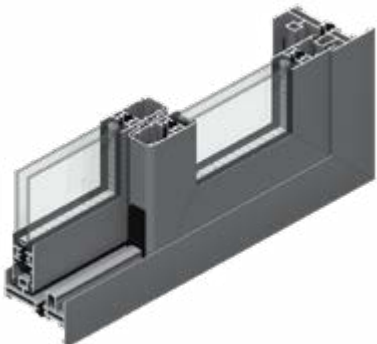

SLIDING WINDOW

2-SIDED
50 SG



CURTAIN WALL

4-SIDED
CW 60

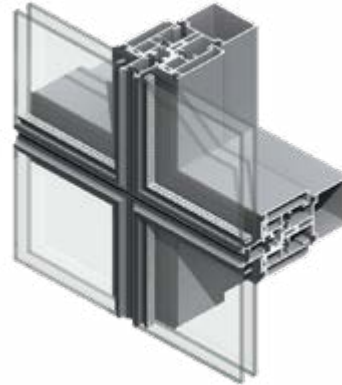

CURTAIN WALL

4-SIDED
50 SG



CURTAIN WALL

4-CONVENTIONEL
50 SG



CURTAIN WALL



ANNA STARBUILT ALUMINUM FACTORY



STRUCTURAL GLAZING SYSTEMS

4-SIDED
CW 60

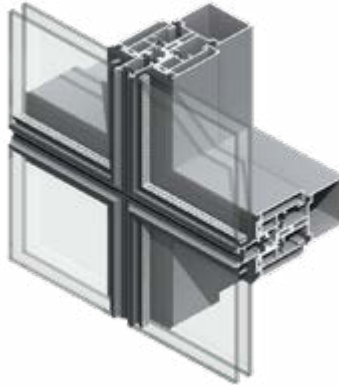

CURTAIN WALL

4-SIDED
50 SG



CURTAIN WALL



ANNA STARBUILT ALUMINUM COMPANY



PIVOT
SYSTEMS

THERMAL BREAK

52MM F - 59MM S



PIVOT WINDOWS

PIVOT

100 & 105MM F - 52MM S



PIVOT WINDOWS

ANNA STARBUILT ALUMINUM COMPANY



SKYLIGHT

SYSTEMS

2-SIDED
50 SG



CURTAIN WALL

4-SIDED
CW 60

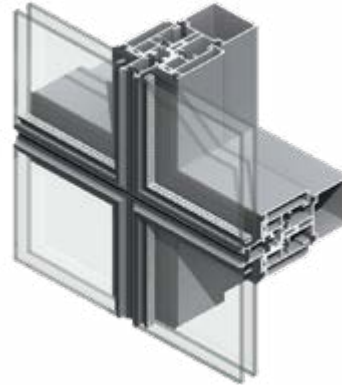

CURTAIN WALL

4-SIDED
50 SG



CURTAIN WALL

4-CONVENTIONEL
50 SG



CURTAIN WALL



ANNA STAR BUILT ALUMINUM COMPANY



LOUVER

SYSTEMS

BACK

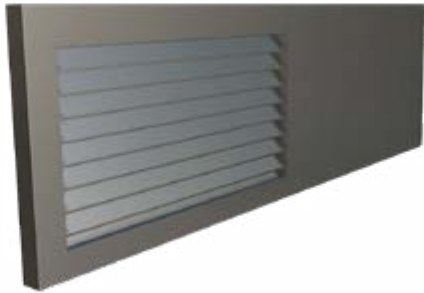

SIDE



FRONT





ANNA STAR BUILT ALUMINUM COMPANY

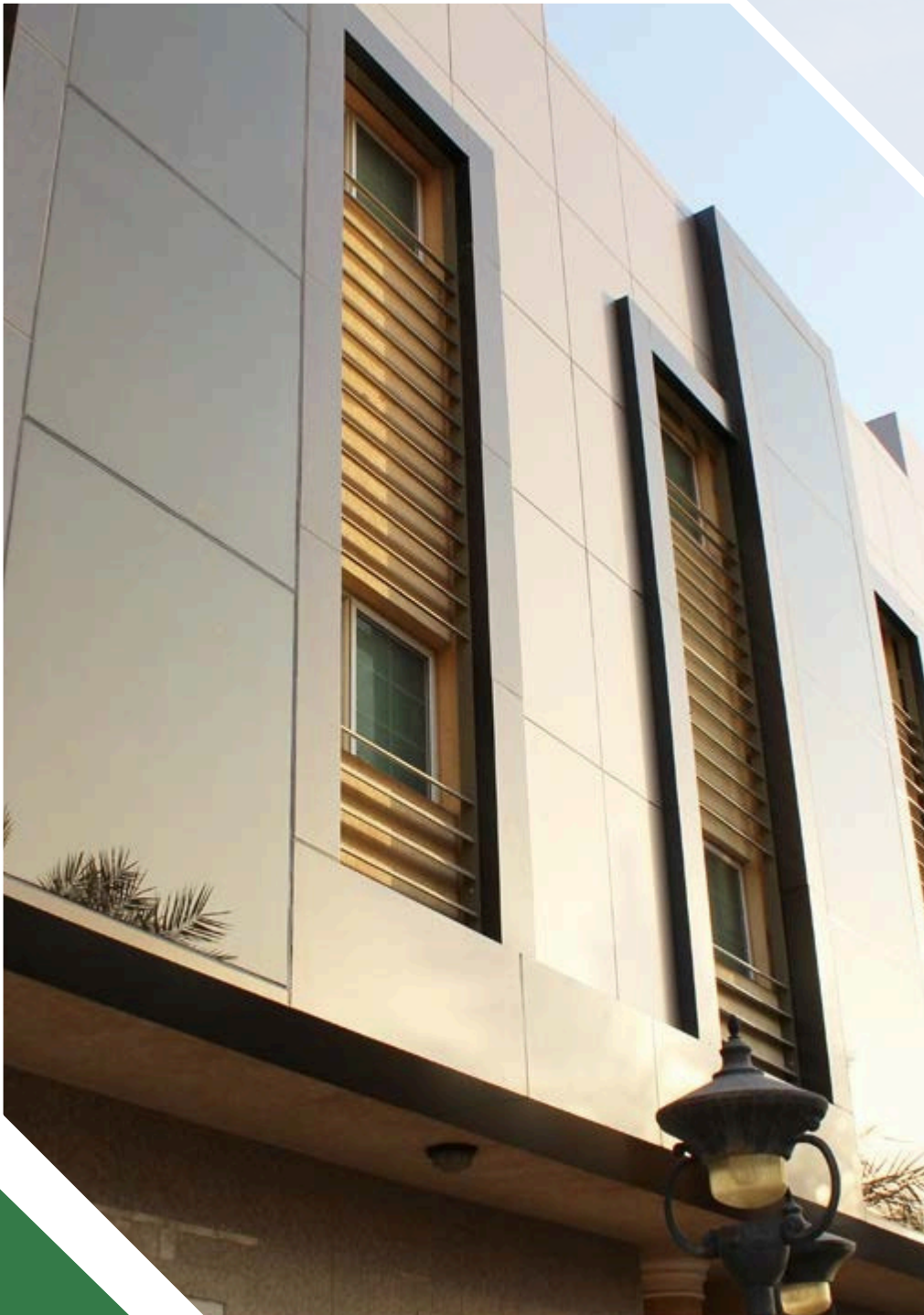

CLADDING

SYSTEMS



ANNA STAR BUILT ALUMINUM COMPANY

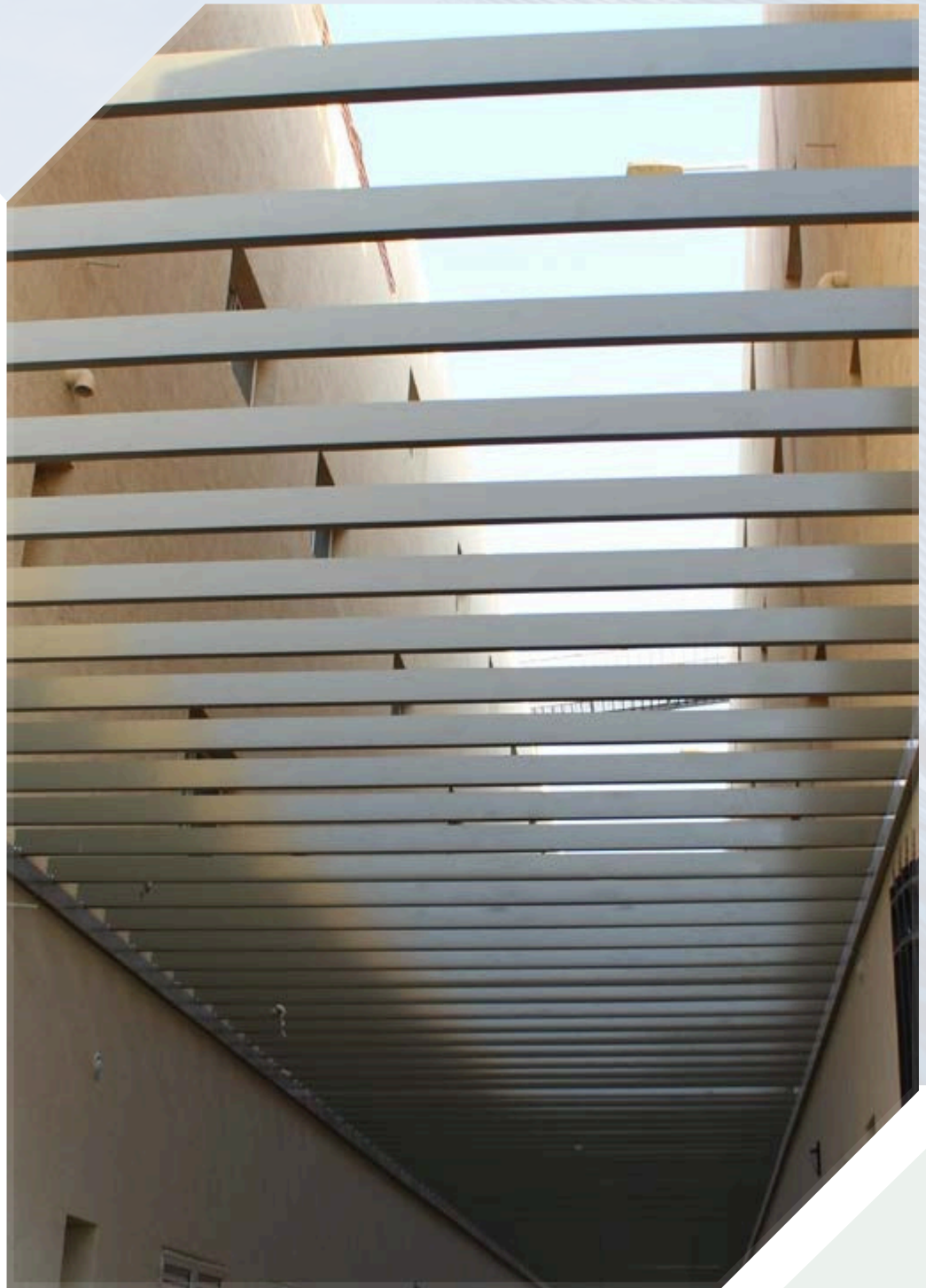

PERGOLA
SYSTEMS



ANNA STAR BUILT ALUMINUM COMPANY



HANDRAIL

ALUMINUM



ANNA STAR BUILT ALUMINUM COMPANY



KITCHEN ALUMINIUM

CABINET



ANNA STAR BUILT ALUMINUM COMPANY





ANNA STAR BUILT

ALUMINUM COMPANY

ORGANAIZATION CHART



 **CENTRALIZED**

 **FACTORY STAFF**



ANNA STAR BUILT ALUMINUM COMPANY





ANNA STARBUILT

ALUMINUM FACTORY

MANUFACTURING FACILITIES

SBZ 141 | SBZ 140 MACHINE



Description

The 4-axis SBZ 141 and SBZ 140 profile machining centres enable convenient, reliable and economical machining of aluminium and thin-walled steel profiles. Thanks to the zero-edge being moved towards the front, profiles can be inserted with exceptional ease. The on-board magazine, which can be equipped with up to eight tools, provides for short tool changing times. Further tool positions are available on request. Different machining lengths, autonomous or automatic clamp positioning, work in shuttle operation: The powerful profile machining centre allows maximum flexibility in routing, drilling and tapping.

CLASSIC MAGIC MACHINE

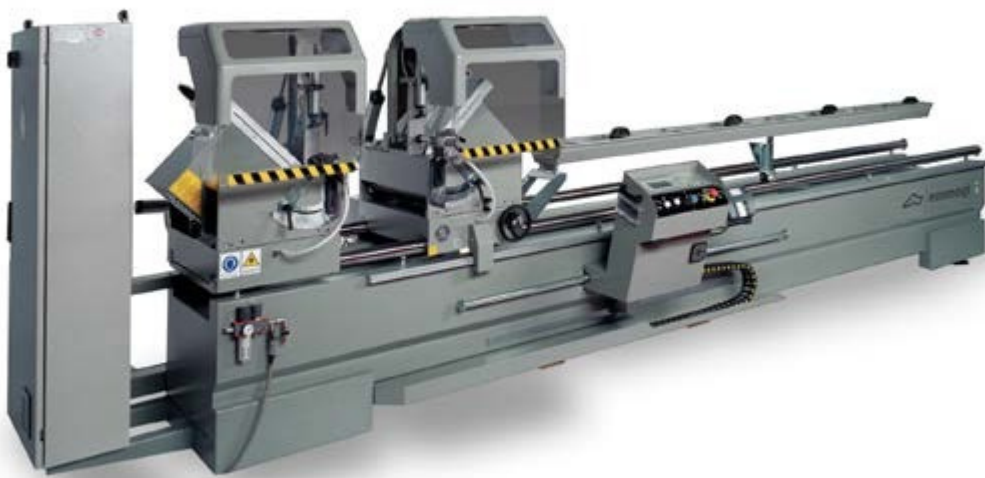

Description

Electronic double-head cutting off machine with automatic movement of the mobile head through a C.C. motor controlled by numerical control. Pneumatic management of all angles up to 30°22' (external). 450 and 500 mm-blade. Available with a useful cut of 6,5,4 m in length.

ALUMINUM CORNER CRIMPING MACHINE



Description

The assembly of the aluminum frame by pressing without screws ensures this speed in production and a good overall shape of the angles

MEPAL SINGLE HEAD MACHINE MODEL RETTA



Description

4 Axis CNC Machining Center able to work 5 profiles faces front, Top, Rear faces and right and left end of the profile - This machine can works all required operations on aluminum profiles such as end milling, holes, copy router, thread and notching , This is to accelerate the production process, achieve the greatest accuracy of measurements, and reduce the number of workers, and the production capacity will be approximately one ton of aluminum.

ASSEMBLY TABLES MACHINE



Description

The assembly stage of windows and doors where accessories are installed

CIRCULAR SAW WITH TILTING BLADE



Description

Formica Cutting Machine Speed and accuracy
in production

SINGLE HEAD CUTTING OFF MACHINE



Description

Aluminum cutting machine for small lengths

COPY MILLING MACHINE



Description

Aluminum Profile Punching Machine for Hinge
Fitting - To ensure accurate fit

ALUMINUM FABRICATION

Aluminum fabrication - Doors & Windows



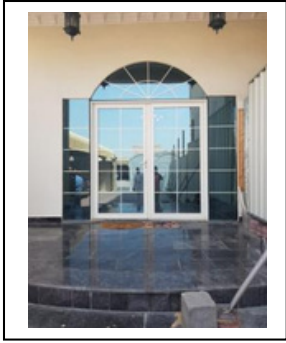

Frameless Glass Doors:

We offer frameless doors made of thick and high quality thin glass which are available in different sizes and shapes. We can fabricate these doors as per client's requirement. They are highly durable and very popular in commercial buildings, super stores, hospitals, residential places, offices etc.



Frameless Glass Partition:

Frameless glass partitions are a superb way to produce privacy or divide rooms without closing an area. We fabricate the frameless glass partitions by using clear glass, which is very popular with residential and commercial clients. Along with it, we also offer glass partitions for every application imaginable.



Shower Cubicles:

Our range of Shower Cubicles comes in every combination that can be imaginable, from self-contained cabinets to screen panels for bays, building into a corner or against a flat wall. A wide range of sliding and bi-fold doors are available can be easily fitted to all the various shaped shower accessories. Durable materials are used to manufacture these shower cubicles like glass, aluminum, copper, stainless steel, brass etc. Shower cubicles represent a complete shower package that offer exceptional value for money.

Aluminum Doors:

We offer aluminum doors that are very durable and reliable. Our aluminum doors show better efficiency and demand less maintenance. Moreover, these aluminum doors are rust proof, with corrosion resistant options and can be availed in reasonable prices.





Aluminum Window:

We make aluminum window by using high quality aluminum. Aluminum windows offered by us are available in various shapes, sizes, designs and colors. They are durable and require less maintenance and care. These windows are rust proof and designed as per the specification given to suit your offices, homes, stores, etc.



Aluminum Partition:

Aluminum partitions are being manufactured by us in a fine way. Such products are used in offices to divide the cabins of employees. We manufacture these partitions as per clients' requirements, and often use good quality of aluminum, glass and other products in making aluminum partitions.



Sound Proof Window:

We manufacture soundproof windows to be used in various organizations. We design such sound proof window after getting clients specifications. They are easy to install and better for noise control, better insulation, no mess or construction required.

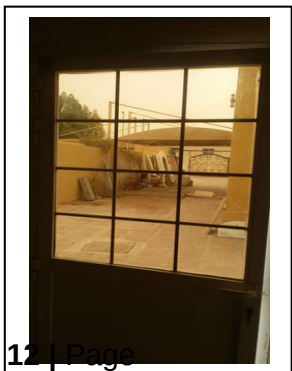

Spider Glazing:

We are specialized in fabricating spider glazing, and such products are made of high quality steels and glass. As soon as we receive the specifications from the client's side, we manufacture the spider glazing from them. Such products are extensively employed in different offices, complexes and malls.

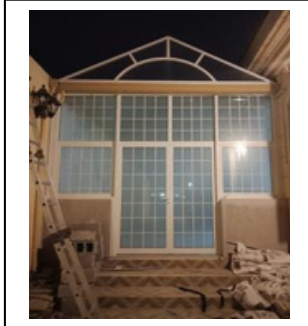

Main Entrance Canopy:

We offer the main entrance canopy in a complete range which is made of high quality stainless steel and glass. Such canopy will be easy-to install and maintain, and has been offered in a variety of designs, styles and shapes. In addition to it, main entrance canopy is customized as per the specifications of the clients.



Toughened Glass:

We offer toughened glass that is safe and strength heat resistance. Such glass comprises increased strength compared with normal glass and will shatter into small fragments, rather than sharp shards, when broken. It shows enhanced thermal resistance, and breaks into small cuboids and so causes less injury.

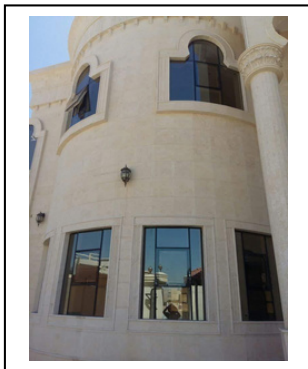

Insulated Glass:

We offer insulated glass that takes in two panes of glass separated by a space. This glass allows no movement of outside air into the space as the space itself can be filled with dehydrated air, or with a special gas. Insulated glass can be found in both residential and business construction and it is made almost a must by building codes in many areas as a mandatory energy conservation measure.

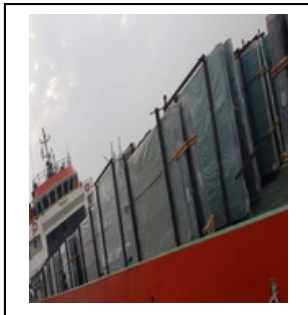

Laminated Glass:

We also offer laminated glasses which are made of thick and tempered laminate glass layer. These Laminated glasses are used in hospitals, shopping malls and banks etc. Apart from such large uses, they can also be employed in staircases in commercial buildings.

Below are our Specialties:

- Tempered Glass in all Thickness
- Glass Partitions for Office and Glass Doors
- Frosted Glass using Sandblast or High Quality Frosted Sticker
- Sliding Glass Door System
- Glass Shower Enclosure/Cubicle with Rust Proof Stainless Steel Accessories
- Replacement of Broken or Damaged Glass
 - Decorative Mirror Installation, Frosted Mirror, Bevelled Mirror, Silver, Grey, Brown
Mirror
- Glass Table Top for Dining Table
- Double Glazed Glass Panel Supply and Installation
- Laminated Glass for Soundproofing and Acoustic Purpose
- Handrail Balustrade Laminated Glass Installation and Replacement
- Aluminium and glass Shop Front Installation
- Stainless Steel Cladding
- Shower Screen Doors
- Glass Bonding
- Glass Joining using UV Glue for Display Showcase Glass for Clean Look
- Aluminium Door and Window
- Balcony Door and Window
- Retractable Fly Screen and Sliding Fly Screen
- Shop Front with Spider Fitting
- Aluminium Louver Gas Cylinder Box

Our Work Gallery







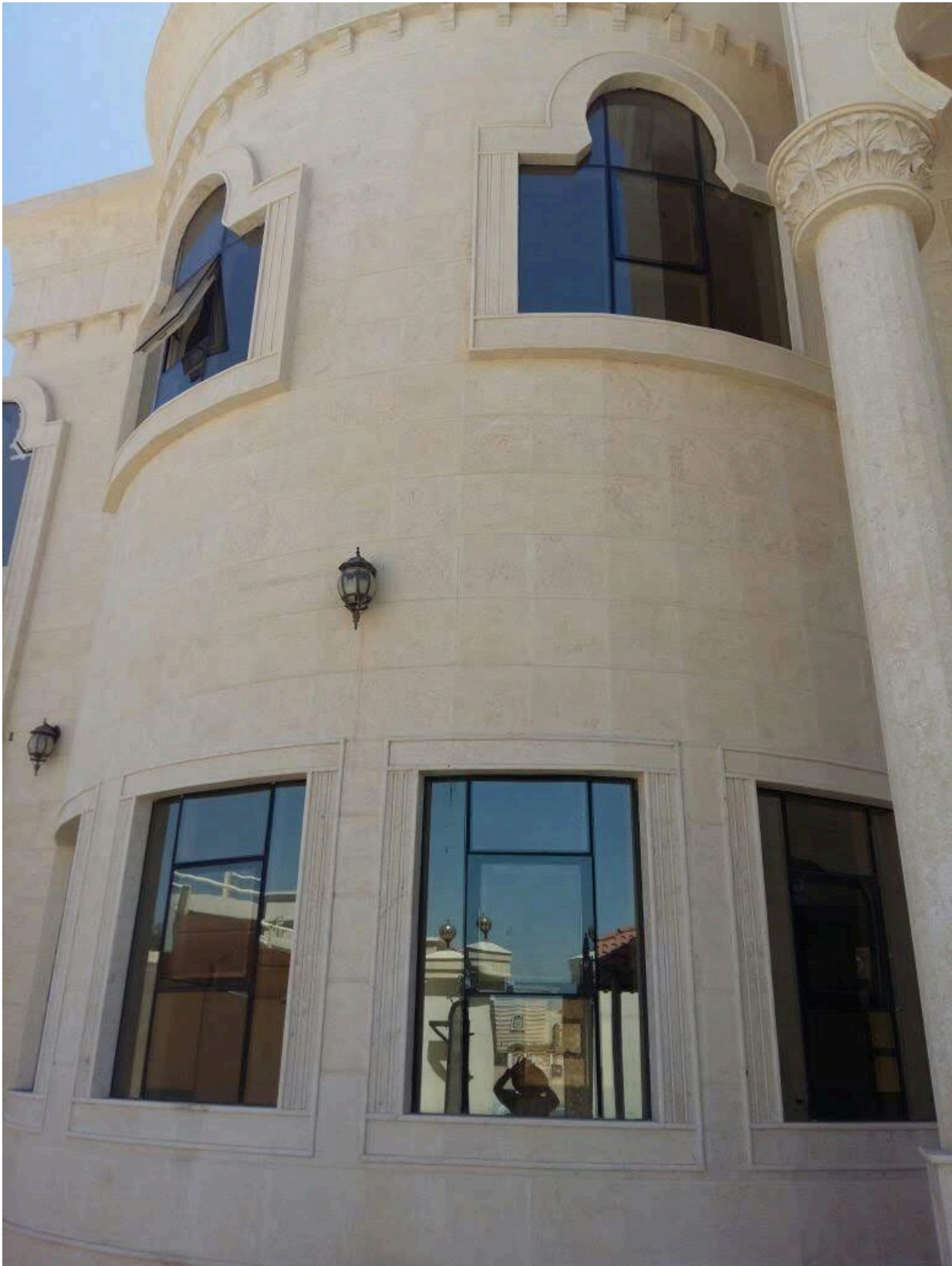















ANNA STAR BUILT ALUMINUM COMPANY













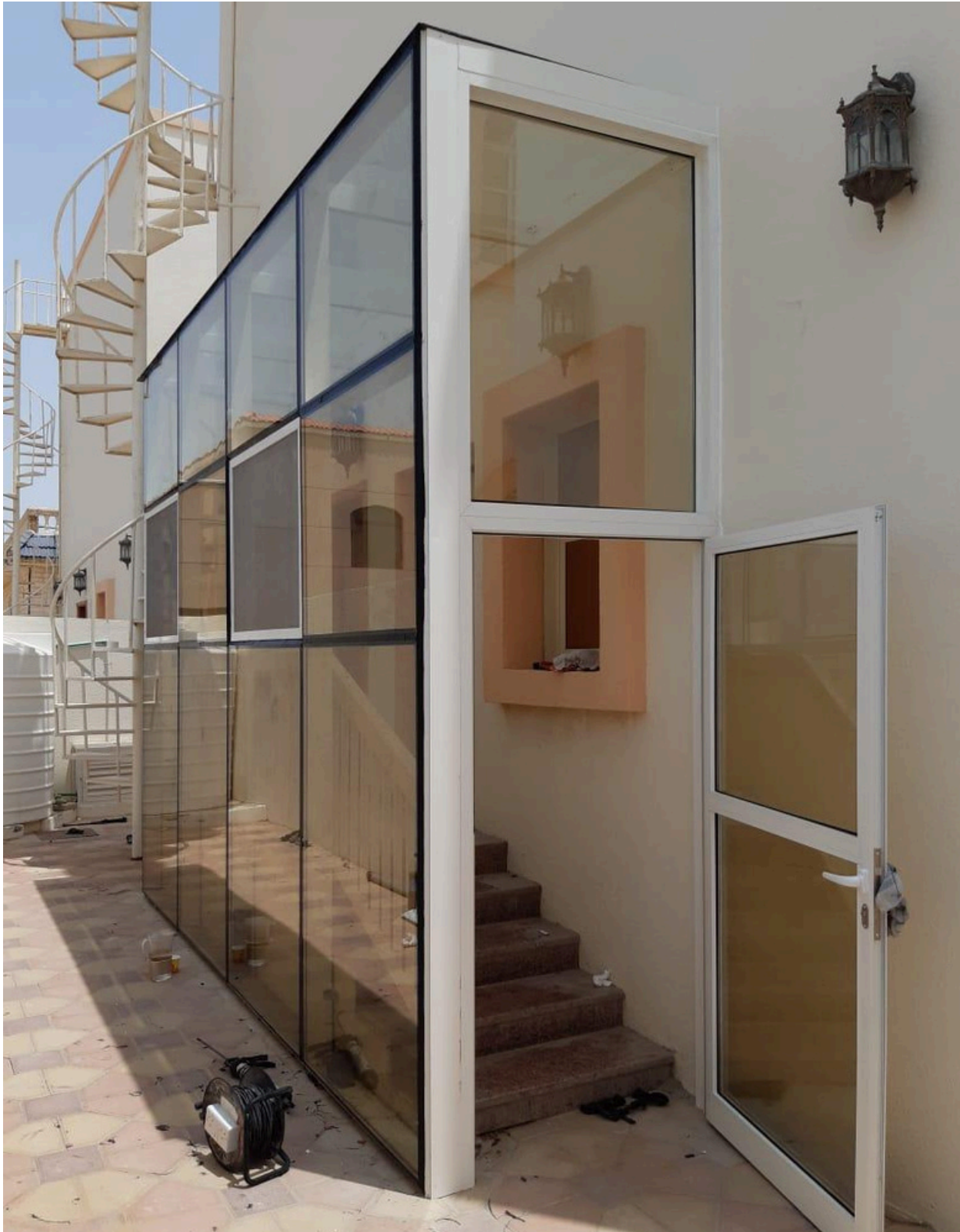





ANNA STAR BUILT ALUMINUM COMPANY



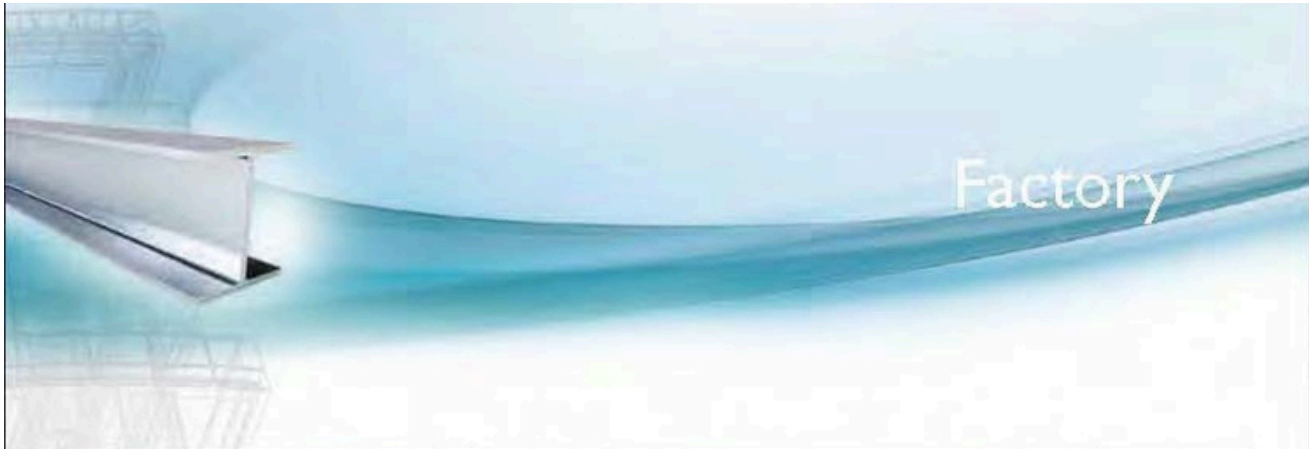

Completed Projects



Completed Projects



Project Name : Ioon Tower
Client : Al Jawi Investments
Consultant : Adnan Saffarini Engineering Consultant
Contractor : Khalifa Al Tajir Contracting Est.



Project Name : Metro Central
Client : Dubai Properties
Consultant : Al Ajmi Engineering Consultants
Contractor : Al Kharbash Contracting Co.



Project Name : The Spirit Tower
Client : Dubai Properties
Consultant : Al Barajeel Engineering Consultant
Contractor : United Engineering Construction



Project Name : G+14 Tecom
Client : Ahmed Ali Abdulla Al Abdulla
Consultant : Rimal Engineering Consultants
Contractor : Gulf Asia Contracting

ALUMINUM FABRICATION

Dispatch Area



Aluminum composite panel





Structural Glazing:

We design and manufacture a wide range of structural glazings that are used in corporate and commercial building construction industry. They are durable and easy to maintain and provide safety from air and water infiltration. They are used in high rise buildings to ensure stability and can be customized as per the specifications of our clients. They are widely used for window frames for buildings, shops, stadiums, complexes etc.



Curtain Wall Glazing:

We fabricate the curtain wall glazing as per clients and expertise instructions. You will be able to achieve complete flexibility with the horizontal sliding, whether it is for shop front, business entrance or partitions. Such glazing endows with a range of exterior appearances, and on the other hand is characterized by closely spaced vertical and horizontal caps with glass or metal infill panels. A finished exterior appearance and sometime a semi-finished interior might be availed with the help of such systems.



Aluminum Composite Panel Glazing:

We offer aluminum composite panel cladding that is largely used in offices, factories, shopping malls, hospitals etc. High quality aluminum is used in making of such panels, which we obtain them from Alucobond, Aludecor, Alomax and other branded organizations. As per the demands of our clients, we also fabricate ACP cladding and comprise a sort of specialization in offering best services to our clients.

ALUMINUM FABRICATION

Dispatch Area

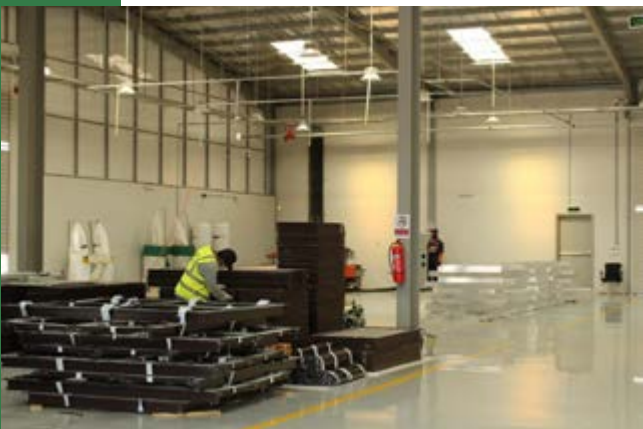

Aluminum composite panel



ALUMINUM FABRICATION



ALUMINUM FABRICATION



ALUMINUM FABRICATION



ALUMINUM FABRICATION





ANNA STAR BUILT ALUMINUM COMPANY





ANNA STAR BUILT

ALUMINUM

COMPANY

QUALITY

ASSURANCE

ANNA STAR BUILT ALUMINUM COMPANY

QUALITY ASSURANCE AND THE PROCEDURE OF QUALITY CONTROL QUALITY ASSURANCE & QUALITY CONTROL

A. VISION OF THE QUALITY ASSURANCE & QUALITY CONTROL

- a) The QA/QC vision is to achieve sustained, profitable growth by business which consistently satisfies the needs and expectations of its customers.
- b) This level of quality is achieved through adoption of a system of procedures that reflect the competence of the Company to existing customers, potential customers, and independent auditing authorities.
- c) Achievement of this policy involves all staff, who is individually responsible for the quality of their work, resulting in a continually improving working environment for all. This policy is provided and explained to each employee by the Managing Director or Quality Manager.
- d) To achieve and maintain the required level of assurance the Managing Director retains responsibility for the Quality System with routine operation controlled by the Quality Manager.

B. MISSION OF THE QUALITY ASSURANCE & QUALITY CONTROL

- a) To maintain an effective Quality Assurance System complying with International Standard ISO2015-9001 (Quality Systems).
- b) To achieve and maintain a level of quality which enhances the Company's reputation with customers.
- c) To ensure compliance with relevant statutory and safety requirements.
- d) To endeavor, at all times, to maximize customer satisfaction.

DEFINITION THE PROCEDURE OF THE INTERNAL QA/QC:

Control and Follow up the set of procedures undertaken by main departments in the company like (sales, engineering, procurement and production) for the successful completion of a deal.

WHAT IS REQUIRED TO ENHANCE OUR PROCEDURE?

In order to ensure that the products and/or services are designed, produced, and delivered in a satisfying way to our customer, QA/QC shall be responsible to benefit from the company's resources and make sure the following is effectively done:

1. Enhancing the communication among departments
2. Finding out the obstacles that might cause late deliveries (in sales, engineering, procurement and production)

Generally speaking, those 2 main points are considered as the major ones that we need to focus on in order to minimize complaints and risks for all our deals.

MAJOR ROLES OF THE QA/QC ARE:

1. Satisfying our customer
2. Minimizing the customer complaints
3. Increasing the productivity
4. Decreasing the production cost
5. Facilitating and improving the internal process

ANNA STAR BUILT ALUMINUM COMPANY

QUALITY MANAGEMENT STRATEGY

INTRODUCTION

A quality management strategy to decrease the wastage is used to define the quality techniques and standards to be applied for achieving the required quality level by quality management strategy:

- Procedures
- Tools and techniques.
- Records reporting.
- Timing of quality activities.
- Roles and responsibility.

QUALITY MANAGEMENT PROCEDURES

The quality management procedure as per the Quality Manual and forms should cover the following topics:

Quality Manual

This document details the corporate quality policy and structure of the Company and references appropriate Operating Procedures.

Quality Planning

To achieve our goal to decrease the wastage by Satisfying our customer

Minimizing the customer complaints

Increasing the productivity

Decreasing the production cost

Facilitating and improving the internal process

Quality control

This during applied Quality standards, templates and forms to be employed (e.g. product description, Quality registrar), Definitions of type of quality methods (e.g. inspection) and metrics to be employed in support of quality control

Quality assurance

This during applied the Responsibility of management reviews meeting.

Tools and Techniques

Refers to quality management tools to be used and preference for techniques which used for each step in the quality management procedure.

Records

Will be including the format of Quality register.

Reporting

Any quality management reports that are to be produced

Reporting

Any quality management reports that are to be produced.

Timing of Quality Management Activities

Time of quality management activities are to be undertaken as audits or reference to quality register

Roles and Responsibilities

Roles and responsibilities for quality managing activities including program management



ANNA STAR BUILT ALUMINUM COMPANY





ANNA STAR BUILT

ALUMINUM

COMPANY

PROJECTS

FACILITIES

JAWHARAT ALRASSEIFA PROJECT



LOCATION

Makkah

CLIENT

Ladun

Investment

CONTRACTOR

Company

Built

VALUE

Contracting Co.

SCOPE

SAR 9,800,000

Doors and Windows

ANNA STAR BUILT ALUMINUM COMPANY



VENAN HOUSING PROJECT



LOCATION

Jeddah

CLIENT

Ladun Investment Company

CONTRACTOR

Built Contracting Co.

VALUE

SAR **32,600,000**

SCOPE

Doors, Windows and Auminum Louver

ANNA STAR BUILT ALUMINUM COMPANY



VERTICAL VILLAGE PROJECT



LOCATION

Alkhobar

CLIENT

Raduim Company

CONTRACTOR

Raduim

VALUE

SAR 730,000

SCOPE

Supply and install 120
kitchen



PRIVATE VILLA PROJECT



LOCATION

Riyadh

CLIENT

Private

CONTRACTOR

Private

VALUE

SAR -

SCOPE

Install ux Doors & Windows



REAL ESTATE DEVELOPMENT FUND PROJECT



LOCATION

Riyad

CLIENT

Real Estate Development Fund

CONTRACTOR

Ladun

VALUE

SAR 17,700,000

SCOPE

Curtain Wall, Glass Partitions, Acoustical Ceiling
& Skylight

ANNA STAR BUILT ALUMINUM COMPANY



RIYAD BANK PROJECT



LOCATION

Riyad

CLIENT

Riyad Bank

CONTRACTOR

Daymat Fitout

VALUE

SAR **13,244,000**

SCOPE

Curtain Wall, Glass Partitions
& Acoustical Ceiling

ANNA STAR BUILT ALUMINUM COMPANY



ASEER MALL PROJECT



LOCATION

Asir

CLIENT

Ajwa Aseer Real State Investment

CONTRACTOR

Company Daymat Fitout

VALUE

SAR **37,950,000**

SCOPE

Curtain Wall, Glass Partitions,
Facade & Acoustical Ceiling

ANNA STAR BUILT ALUMINUM COMPANY



ADMINISTRATION BUILDING FOR MINISTRY OF DEFENSE



LOCATION

Riyad

CLIENT

Ministry of Defense

CONTRACTOR

Built contracting

VALUE

SAR **25,000,000**

SCOPE

Façade - Doors & Windows

ANNA STAR BUILT ALUMINUM COMPANY



ALMALQA RESIDENCE PROJECT



LOCATION

Riyad

CLIENT

Alkhabeer

Investment

CONTRACTOR

Company

Alkhabeer

VALUE

Investment Company

SCOPE

SAR 4,170,000

Curtain Wall, ACD & Pergolas

ANNA STAR BUILT ALUMINUM COMPANY



KAP4 - MINISTRY OF INTERIOR PROJECT



LOCATION

Tabuk - Site No.:124

CLIENT

Ministry of Interior

CONTRACTOR

Al Arrab Contracting Company

VALUE

SAR 1,982,250

SCOPE

Aluminum Kitchen Cabinets with Counter Tops

ANNA STAR BUILT ALUMINUM COMPANY







ANNA STAR BUILT ALUMINIUM COMPANY

FACTORY

CERTIFICATE



100241101284962

TIN 3121007321 الرقم المميز
Certificate No. 100241101284962 رقم الشهادة
Certificate date 12/03/2024 تاريخ الشهادة



هيئة الزكاة والضريبة والجمارك
Zakat, Tax and Customs Authority

المملكة العربية السعودية
Kingdom of Saudi Arabia

شهادة تسجيل في ضريبة القيمة المضافة

VAT Registration Certificate

تشهد هيئة الزكاة والضريبة والجمارك بأن المكلف أدناه مسجل في ضريبة القيمة المضافة بتاريخ ٢٠٢٤/٠٣/١٢ م
The Zakat, Tax and Customs Authority certifies that taxpayer below is VAT registered on 12/03/2024 AD

Taxpayer Name	شركة آنا ستار للمقاولات	اسم المكلف
VAT Registration Number	312100732100003	رقم التسجيل الضريبي
Effective Registration Date	2024/04/01	تاريخ نفاذ التسجيل
Taxpayer Address	الرياض، الرياض، عويضة، 12836	عنوان المكلف
CR / License		رقم السجل التجاري
Contact / ID No	1010992357	الرقم / الرخصة / العقد / الهوية
Tax Period	ربع سنوي-Quarterly	الفترة الضريبية
First Filing due date	2024/07/31	تاريخ استحقاق أول إقرار ضريبي

ملاحظة كمكلفين مسجلين في ضريبة القيمة المضافة لا يجوز لكم تحصيل ضريبة القيمة المضافة من عملائكم قبل تاريخ نفاذ التسجيل في الضريبة وفي حال تبين غير ذلك ستقوم هيئة الزكاة والضريبة والجمارك بتنفيذ الغرامات المستحقة

Note: As a VAT registered taxpayer, you are not allowed to collect VAT from your customers prior to the effective date of the tax registration. If otherwise approved, The ZAKAT, Tax and Customs Authority will impose the applicable penalties



ف تسجيل في ضريبة القيمة المضافة، لا يجوز لك تحصيل ضريبة القيمة المضافة من عملائك قبل تاريخ
ذ التسجيل بالضريبة. في حال تبين غير ذلك، ستقوم الهيئة العامة للزكاة والدخل بتنفيذ الغرامات



ANNA STARBUILT ALUMINUM FACTORY

CERTIFICATE



شهادة اشتراك
Membership Certificate

غرفة الرياض
Riyadh Chamber

Membership No. :	914592	914592	رقم العضوية الموحد :
Date of Issue:	05/03/2024	2024/03/05	تاريخ الاصدار:
Membership Class :	Sixth	السادسة	درجة العضوية :
Riyadh Chamber Certifies			تشهد الغرفة التجارية الصناعية بالرياض بأن شركة آنا ستار للمقاولات
Commercial Registration	1010992357	1010992357	مقيدة بالسجل التجاري / الترخيص رقم :
No. Certificate Expires on	23/02/2025	2025/02/23	ينتهي سريان هذه الشهادة في





الخدمات الإلكترونية لغرفة الرياض - بوابة أعمال © E-Services Riyadh Chamber

920004565

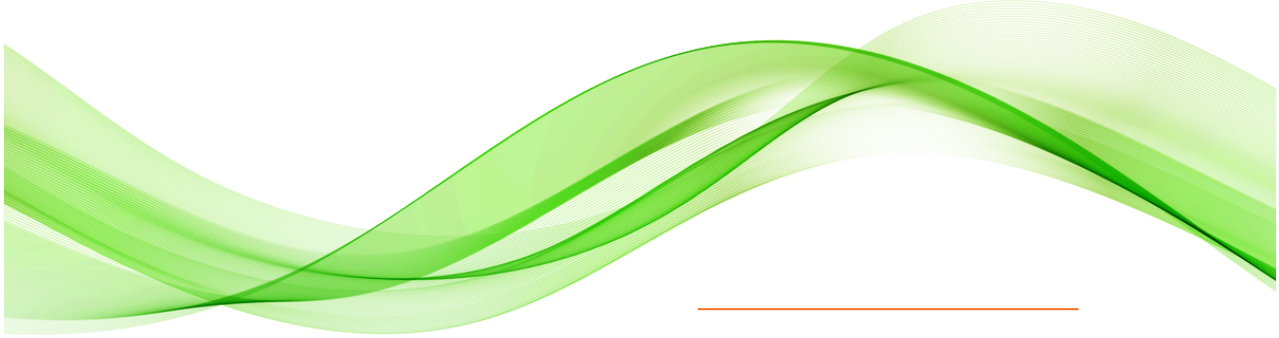
- يلزم التحقق من الوثيقة عبر الرابط <https://mybusiness.chamber.sa> ، أو تطبيق (سند) للأجهزة المحمولة أو الرقم الموحد دون ادنى مسؤولية على الغرفة عن محتوى الوثيقة.
- تعد هذه الورقة من الوثائق الإلكترونية لغرفة الرياض، ويمنع تعديلها أول محاولة العبث بها وتصبح لاغية حال محاولة تعديلها وتعرض صاحبها للملاحقة القانونية.



**Anna Star Company Are
ISO Register**

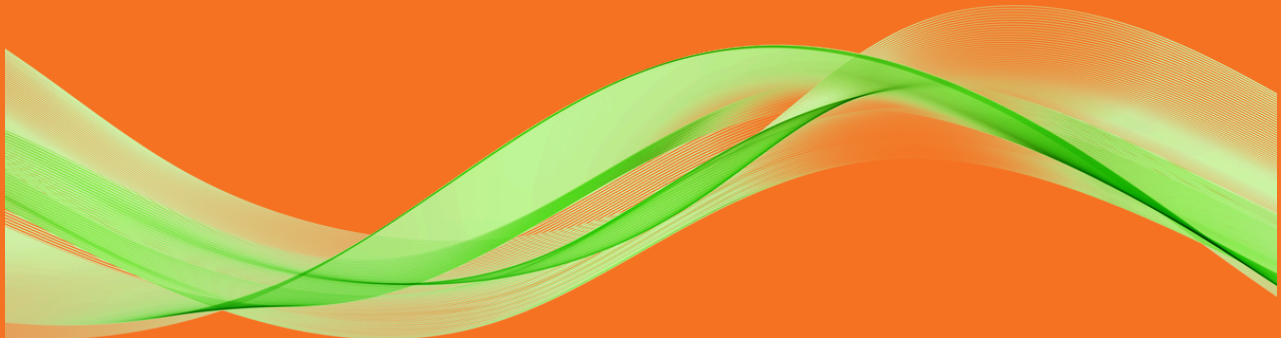

Certificate



Certificate of Compliance

This is to certify that management system of

ANNA-STAR CONTRACTING COMPANY

Postal code 12836, Building number 3454, Uwaidah street, Al-Malaz Dist. Riyadh city kingdom Of Saudi Arabia.

follows proper Quality Management System according to
ISO 9001:2015 to maintain manufacture and sales of
Anna Star Contracting Company
and timely take all necessary step to achieve QMS's
measures for the purpose of Construction and Contracting Company.

Date of Registration	: 27	sep
1st Surveillance Due	: 2024	26
2nd Surveillance Due	: sep	2025
Certificate Expiry (subject to the company maintaining its system to the required standard)	: 26	sep
	2026	26
		sep 2027

Certificate# 502147894

To Verify Certificate Contact through info@quality-veritas.com



Jamil
Authorised Signatory

Quality Veritas Limited

Validity of this certificate is subject to annual surveillance audits done successfully

www.quality-veritas.com info@quality-veritas.com

Address: 9th Bankwell Street Manchester M15 5LN



Certificate of Compliance

This is to certify that the Environment Management System of

ANNA-STAR CONTRACTING COMPANY

Postal code 12836, Building number 3454, Uwaidah street, Al-Malaz Dist. Riyadh city kingdom Of Saudi Arabia.

Has been independently assessed and is compliant
with the requirements of

ISO 45001:2018

Occupational health and Safety Management System

This certificate is applicable to the following product of services ranges

Construction and Contracting

Certificate NO: AE 100000567/03/H

Dots of this cortificate 03 April 2024 Date of initial Registration 03 April 2025

Date of Certificate Expiry 02 April 2026 Re-Certification Due 02 April 2027

This certificate is the property of Anna Star Contracting Company certification and remains valid Subject to satisfactory surveillance audits.

Director



Certificate



Certificate of Compliance

This is to certify that management system of

ANNA-STAR CONTRACTING COMPANY

Postal code 12836, Building number 3454, Uwaidah street, Al-Malaz Dist. Riyadh city kingdom Of Saudi Arabia.

follows proper management system according to
ISO 14001: 2015 to maintain health and safety systems and timely take all necessary steps to access and maintain health and safety measures among their working staffs and labour.

Date of Registration	: 27	sep
1st Surveillance Due	: 2024	26
2nd Surveillance Due	: sep	2025
Certificate Expiry (subject to the company maintaining its system to the required standard)	: 26	sep
	2026	26

Certificate# 503167874 sep 2027

To Verify Certificate Contact through info@quality-veritas.com



Janil
Authorised Signatory

Quality Veritas Limited

Validity of this certificate is subject to annual surveillance audits done successfully

www.quality-veritas.com info@quality-veritas.com

Address: 9th Bankwell Street Manchester M15 5LN





ANNA STAR BUILT ALUMINUM COMPANY

Thank you



Email
info@ana-grp.com



Telephone
[+966558490607](tel:+966558490607)



Website
www.ana-grp.com